

P DETAIL 5 : 1

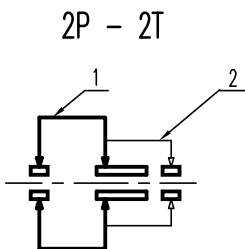

SCHMATIC

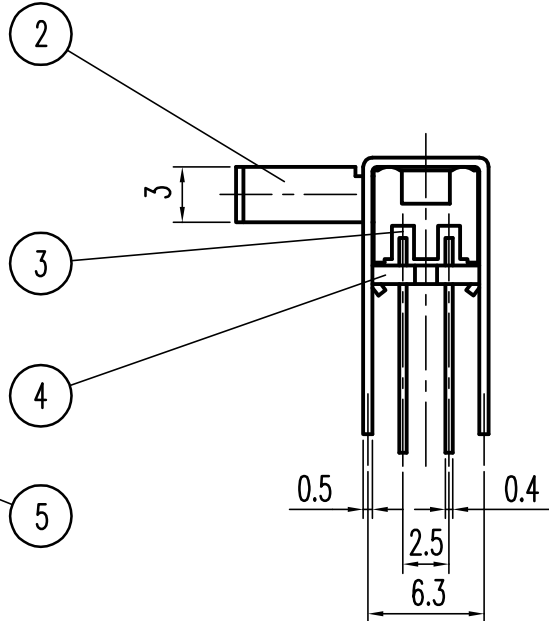
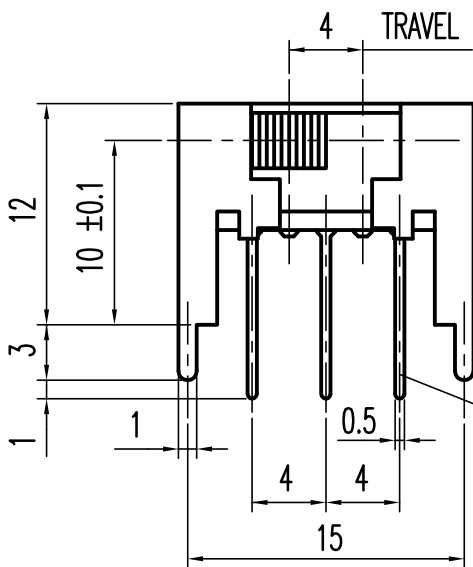
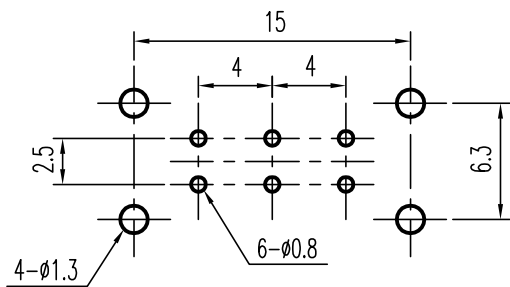

PIERCING PLAN

5	TERMINAL	C2680R-EH	6	Ag PLATED				
4	TERMINAL BASE	PHENOL RESIN	1	NATURAL				
3	CONTACT	C5210R-EH/Ag CLAD	2	NATURAL				
2	KNOB	P O M	1	G 2 - 9				
1	FRAME	S P C C	1	Ni PLATED	REV	DESCRIPTION	SIGN.	DATE
NO	PART	MATERIAL	QTY	REMARKS	VERSION 01	DWG NO. ITEM1896		

TOLERANCES UNLESS OTHERWISE SPEC.		TITLE	SIDE KNOB SLIDE SWITCH	ITEM NO.	SK-22H12-G			
UNDER 1	± 0.10	DRAWN	L . F . L A I	10 DEC 98	SCALE	3 : 1	UNIT	mm
1 - 10	± 0.30	APPROVED			PROJECTION			
OVER 10	± 0.50							

COMAX INDUSTRIAL CO., LTD.